

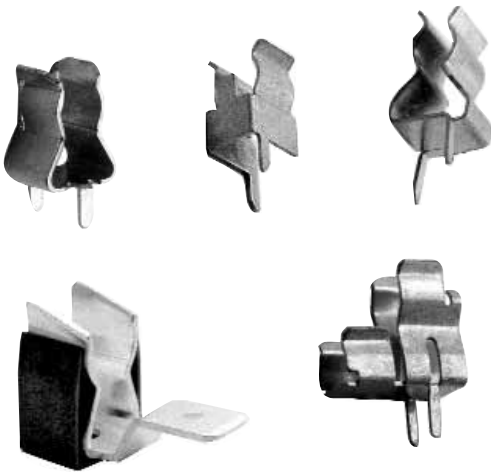

Gears & Fuse Gears

All Fuse Clips



5x20 and 6x32 Fuse sizes

- CLIPS FOR PRINTED CIRCUIT BOARD OR SCREW MOUNTING
- RATED CURRENT BELOW 30A* DEPENDING ON TYPE

Main Characteristics

Size	Rated Current A	Power acceptance W 23°C	End Stops	Monting	Material	Designation	Reference Number	in box of 1000pcs	blister of 50pcs	Catalog Number
5x20	6,3*	1,6	Yes	Printed circuitboard	Brass, Tin plated	MR 5 CI.SP	W202074	Yes	Yes	MIMR5CISP
5x20	6,3*	2	Yes	Printed circuitboard	Brass, Tin plated	MR 5 CI-S	J210550	Yes	Yes	MIMR5CI-S
5x20	6,3*	2,5	Yes	Printed circuitboard	Bronze, Tin plated	MR 5 CI-C	K210551	Yes	Yes	MIMR5CI-C
5x20 & 6x32	6,3*	1,6	No	Printed circuitboard	Brass, Nickel plated	MR 5-6	Y098967	Yes	Yes	MIMR5-6
5x20 & 6x32	6,3*	1,6	Yes	Printed circuitboard	Brass, Tin plated	MR 5-6.SP	C204955	No	Yes	MIMR5-6SP
6x32	10*	2,5	Yes	Printed circuitboard	Bronze, Tin plated	MR 6 CI-S	H210549	Yes	Yes	MIMR6CIS
6x32	30*	3,5	No	Screw mounting 6,3mm slip-on connector tags	Silver plated copper + stainless steel spring	MR 6 VI	K091480	No	Yes	MIMR6VI

* Depends on fuse cover number for 5x20. L210552P

MR 5 CI.SP:

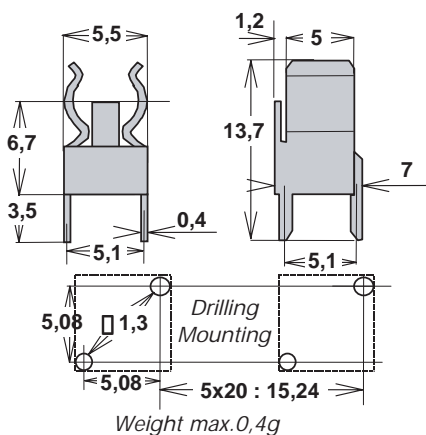

MR 5 CI.S:

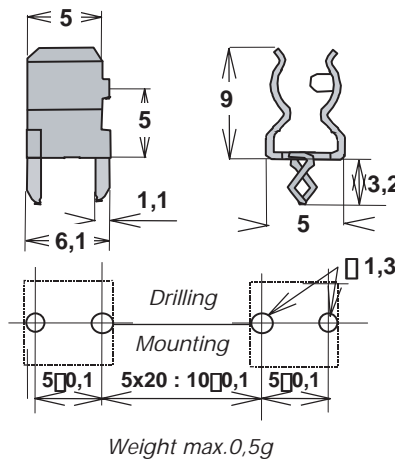

MR 5 CI.C:

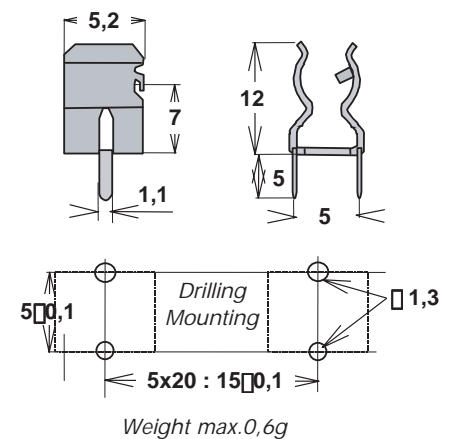



All Fuse Clips



5x20 and 6x32 Fuse sizes

MR 5 - 6:

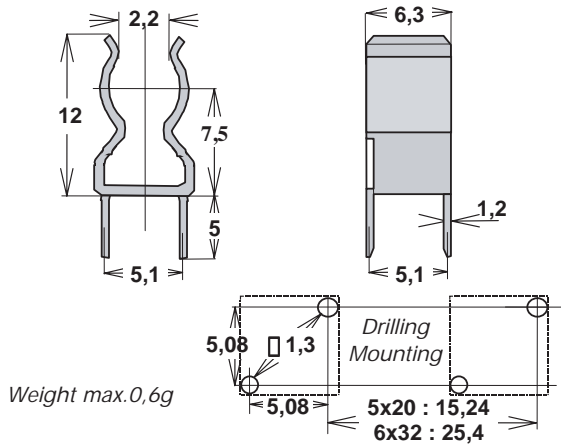

MR 5 - 6 SP:

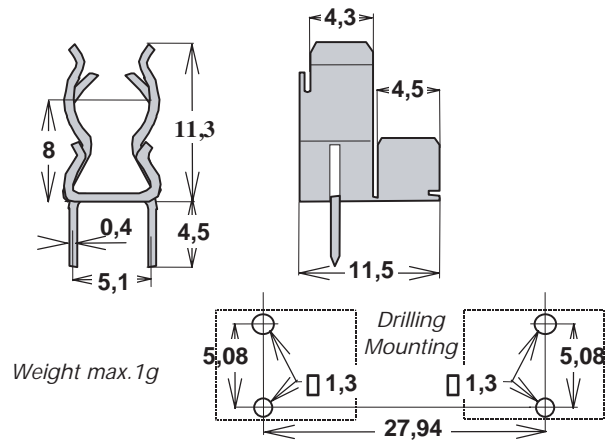

MR 6 CI - S :

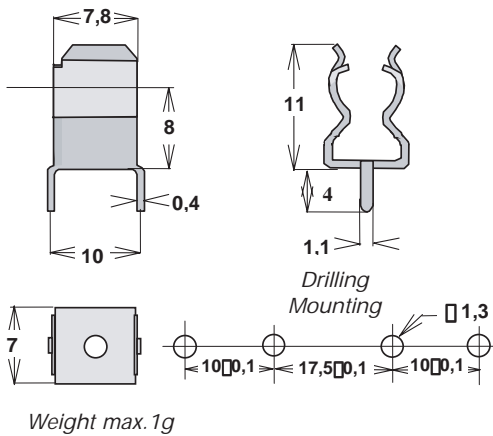

MR 6 VI :

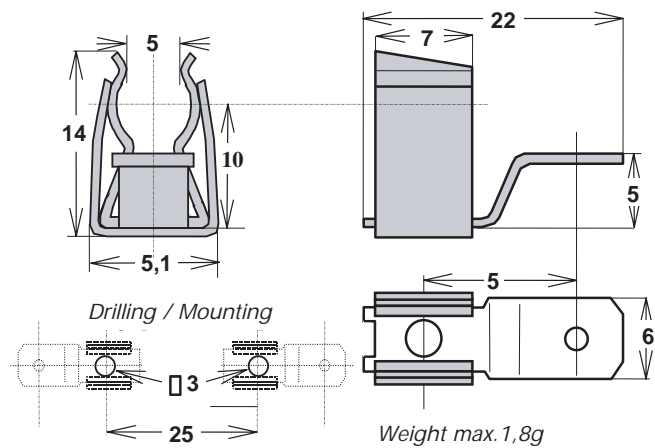

CPT 5x20 FOR MR5CI-C & MR5-6:

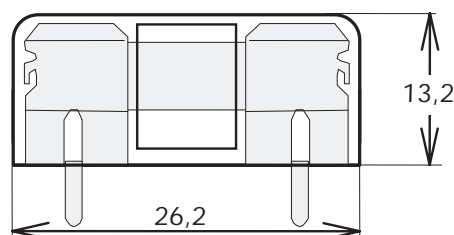



All Fuse Clips



for Ferrule fuses / pc board
30A & 60A ferrule - fuse clips

Fuse Clips for 30 & 60 Ampere Ferrule-type Fuses

Cat. Num.	Ref. Num.	Fig.	For Fuse Rating/Size:		Mounting Details	
			Amps (max.)	Ferrule Dia.	Hole Size	Screw Size
CO8915P	R215479	1	30	13/32"	.172" dia.	#8
CO8919P	P217524	2	30	13/32"	.196" dia.	#10
CO8916P	V215988	3	30	9/16"	.172" dia.	#8
CO8917P	R216491	4	30 or 60	13/16"	.22" x .30"	#10
CO8918P	F217010	5	60	1-1/16"	.22" x .30"	#10

All clips are UL Recognized: Guide IZLT2, File E52283

All clips are tin-plated copper alloy, non-spring reinforced.

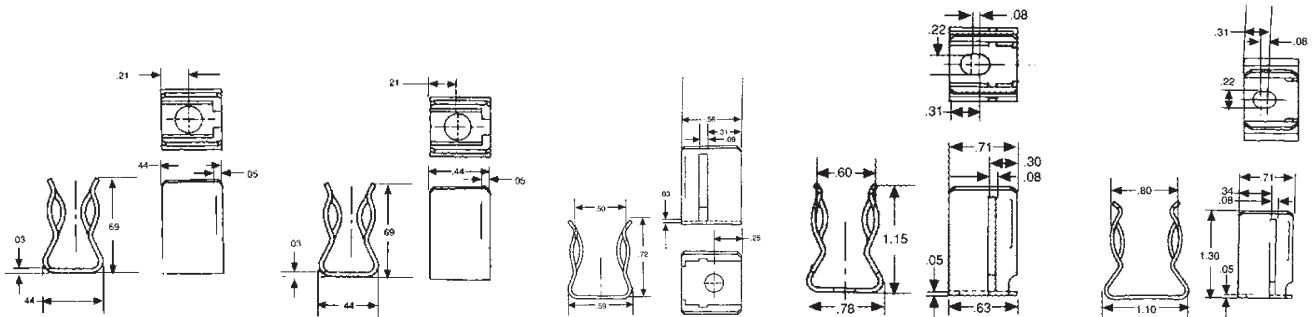

Figure 1

Figure 2

Figure 3

Figure 4

Figure 5

SDC6 - K222051 PC BOARD clips

- PC board mount fuse clip
- For 1/4" diameter fuses
- Tin plated hard brass
- 15A maxi

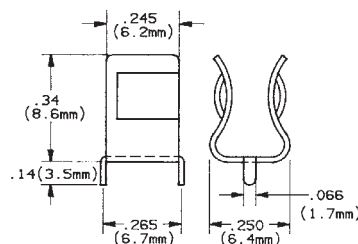

SDC5 - R219596 PC BOARD clips

- PC board mount fuse clip
- For 5mm diameter fuses
- Tin plated hard brass
- 10A maxi

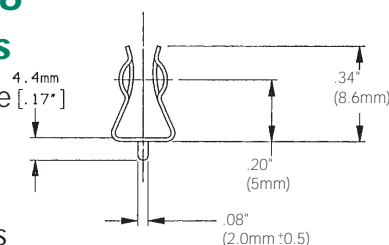

SDC7 - T222795 PC BOARD clips

- PC board mount fuse clip
- For 13/32" (10mm) diameter fuses
- Tin plated spring brass
- 30A maxi

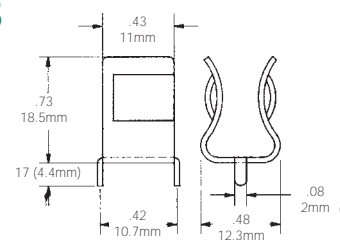



All Fuse Clips



For Ferrule style Fuses

Ø 10 - 14 - 22 - 27 - 36 - 45 - 55

- SILVER-PLATED COPPER CLIPS: EXTREMELY HIGH THERMAL AND ELECTRIC CONDUCTIVITY
- MOUNTING TYPE:
 - SCREWING ON ISOLATORS
 - SCREWING ON BARS OR INSULATED BARS
 - WELDING ON P.C.B. (MR 10 CI)
- STAINLESS STEEL PRESSURE SPRINGS: HIGHLY RESISTANT TO SALT SPRAY

Main Characteristics

Designation	Current rating IN (A)	Maximum R.M.S continuous current through IN - rated current fuses (A)	Recommended copper cable section (mm ²)
MR 10	32	32	4
MR 10 CI	32	32	4
MR 14	63	63	10
MR 20	125	125	35
MR 22	135	135	35
MR 27	250	250	120
MR 36	250	250	120
MR 45	525	525	-
MR 55	750	750	-

MR 10 - MR 10 CI

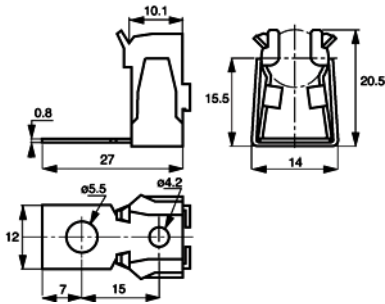

Catalog Number	Designation	Ref. Number	Weight (g)	Packaging
MR10RESSORT	MR 10	B098004	7	20 pieces

Catalog Number	Designation	Ref. Number	Weight (g)	Packaging
MR10RESSORTSP	MR 10 without connection	C098994	5,7	20 pieces

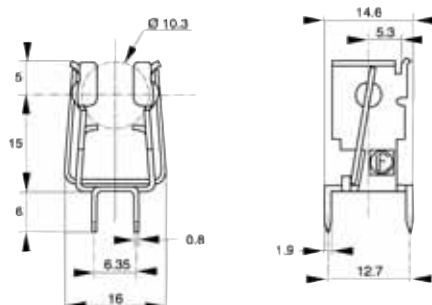
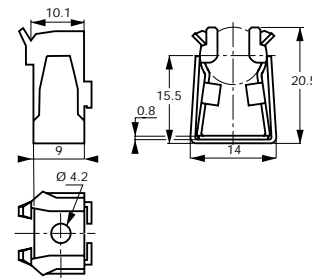

Catalog Number	Designation	Ref. Number	Weight (g)	Packaging
MR10RESSORTCI	MR 10 CI	Y098507	4,5	200 pieces



All Fuse Clips

For Ferrule style Fuses
Ø 10 - 14 - 22 - 27 - 36

MR 14

Catalog Number	Designation	Ref. Number	Weight (g)	Packaging
MR14SPRING	MR 14	G098170	16	10 pieces

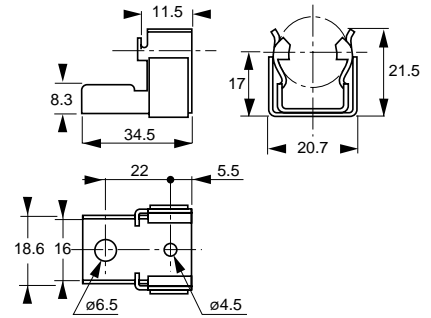

MR 20.6

Catalog Number	Designation	Ref. Number	Weight (g)	Packaging
MR20RESSORT	MR 20.6	H099988	40	20 pieces

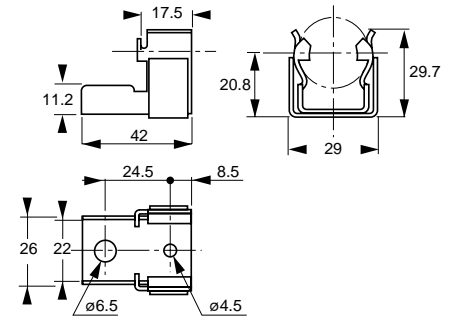

MR 22

Catalog Number	Designation	Ref. Number	Weight (g)	Packaging
MR22SPRING	MR 22	K098909	40	10 pieces

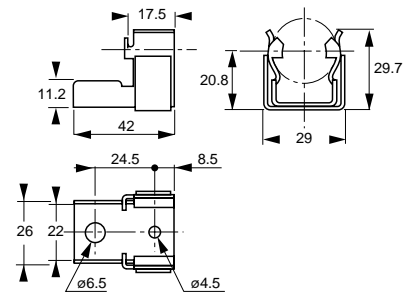

MR 27

Catalog Number	Designation	Ref. Number	Weight (g)	Packaging
MR27RESSORT	MR 27	Y092734	50	20 pieces

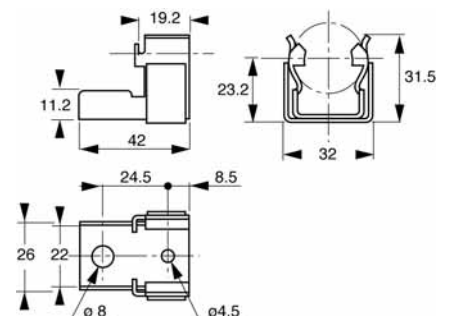



All Fuse Clips

For Ferrule style Fuses
 \varnothing 10 - 14 - 22 - 27 - 36

MR 36

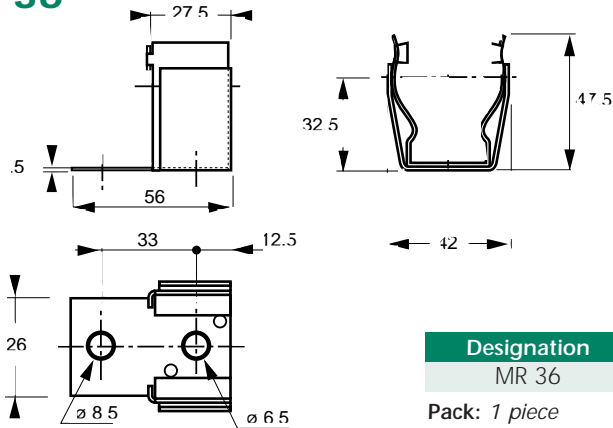

Designation	Ref. Number	Weight (g)	Catalog Number
MR 36	M091275	85	MR36R

Pack: 1 piece

All clips silver-plated copper with stainless steel springs.

Mounting Instructions

P.C.B. Drilling for MR10 CI clip (10 X 38 Size Fuse)

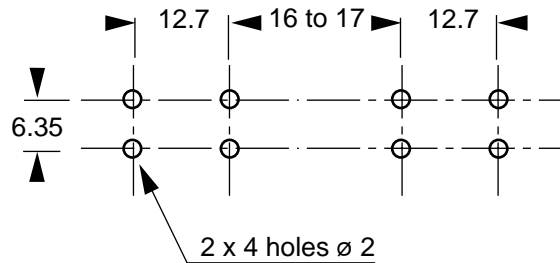

Clip Mounting

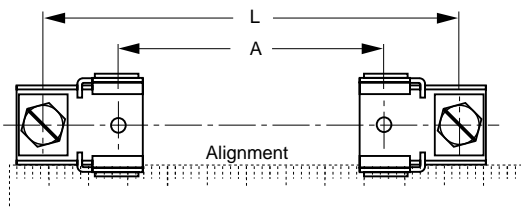

Fuse size	A	L
10 x 38	31	61
14 x 51	42	86
22 x 58	42	91
20 x 51	36	85
20 x 127	113	162
20 x 190	175	224
27 x 60	41	91
36 x 127	100	148
36 x 190	165	231

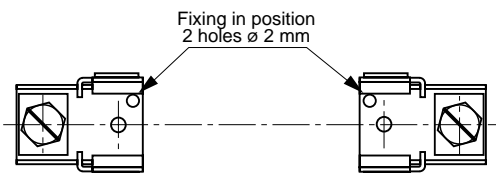

Mounting of two elastic stop pins of 2 mm dia. for fixing clips in position



Gears & Fuse Gears

All Fuse Clips



Dimensions MR45 - MR55

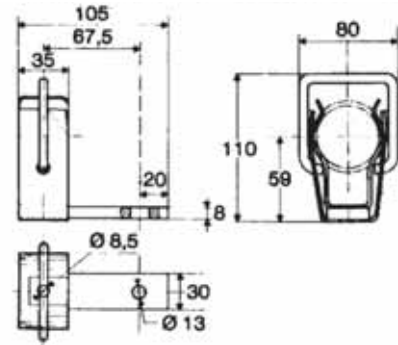
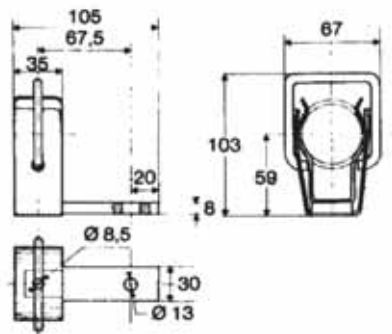

For fuse diameter	Designation	Reference Number	Catalog Number	Material ensuring the electrical contact (1)	Thermal current I _{th} (A)	Weight (g)
45	MR 45	L09647	MR45R	Silver-plated copper	525	450
55	MR55	L078969	MR55R	Silver-plated copper	750	450

Packaging: 1 piece

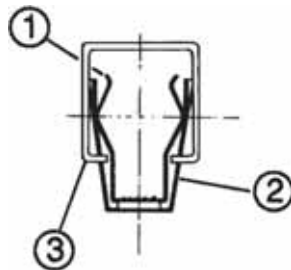

All the clips are made of an electrical contact (1) and a spring in stainless steel (2).
The clip MR 45 and MR 55 have also a padlocking system (3) which enables to stop in rotation the heavy fuses.



All Fuse Clips

Clip lock design for CL-14 series

The Clip Lock design provides a reliable, high-pressure contact. Ferraz Shawmut CL-14 fuses have copper tabs which slide into position between the clip casting and cam. When the cam is locked by moving the pull ring, a high-pressure contact is made between the clip casting and fuse tab. Each clip includes two .44" diameter counter-sunk holes on 2" centers and two flat head socket screws (3/8-16 UNRC, recommended torque 200 pound-inches) for mounting the clip on standard NEMA insulators. These clips will accommodate 5kV and 15kV CL-14 fuses rated 10E to 600E. Order catalog number 228-700-520 for one pair of fuse clips, enough for one fuse.



Cat. No. 228-700-520
(Pair at bottom)

Cat. No. 228-700-530
(Single at top)

Mounting Details for Clip Lock Cat. No. 228-700-520

CL-14 Fuse Catalog Number	A Dimensions - Inches
A055C1DORO-(10E-150E)	13.25
A055C1DORO-(200E-400E)	19.25
A055C2DORO-(450E-600E)	19.25
A155C1DORO-(10E-50E)	19.25
A155C1DORO-(65E-100E)	19.25
A155C2DORO-(125E)	19.25
A155C3DORO-(150E-300E)	19.25

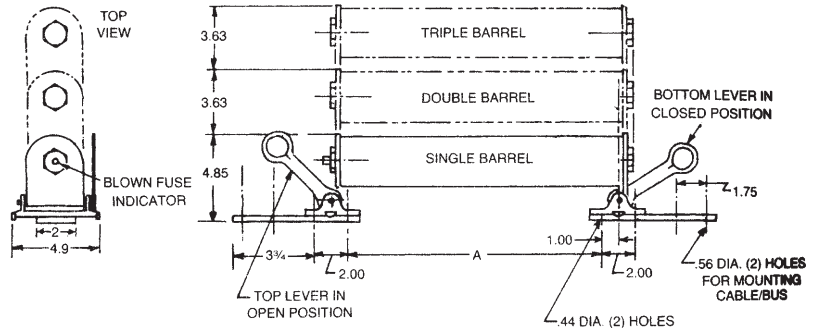

Clips for 3" diameter ferrule fuses

These spring-reinforced clips will accommodate all 3" diameter, one and two barrel E-rated and R-rated medium voltage ferrule-type fuses. The clip and reinforcing spring are intended to be bolted to a copper bus bar through two .41" x 1.06" slots. A minimum copper-bus cross section of 1/4" x 1-1/2" is recommended for maximum fuse ratings of 24R and 450E. Catalog number is 228-700-530 for one pair of spring-reinforced clips, enough for one fuse.

Cat. No. 228-700-530

