



FUSE ADVANTAGES

1. INTRODUCTION

2. FUSE ADVANTAGES

- 3.1. Safety**
- 3.2. Speed**
- 3.3. Breaking capacity**
- 3.4. Maintenance before a short-circuit**
- 3.5. Maintenance after a short-circuit**
- 3.6. Selectivity (or discrimination)**
- 3.7. Power quality**
- 3.8. Future system growth**
- 3.9. Low power consumption**
- 3.10. Reliability**
- 3.11. Universal**
- 3.12. Price**

3. CONCLUSION

1. INTRODUCTION

The first patented fuse was patented by **EDISON** in 1880. It was a simple wire. Modern fuses are the result of more than 100 years of experience. They show a high technical level and have characteristics well adapted to the characteristics of equipments and installations they are protecting. The fuse can protect people and equipments against possible component explosions because it can stop the rise of the short circuit current within milliseconds or less. Calculations and tests show the arc flash energy is drastically reduced when a fuse limits the peak value of the current. The fuse has a lot of advantages such as: high speed, high breaking capacity, improvement of people safety because it is the best **current limiting** device, improvement of the power quality, economical. All above applies to fuses for low and medium voltage distribution circuits as well as for DC circuits.

2. FUSE ADVANTAGES

2.1. Safety

This is a key factor when designing or upgrading an installation. The fuse is still the best because:

- The metallic element inside the fuse melts directly upon the fault current effect without any intermediate mechanism, sensors etc
- The arc extinction is totally enclosed so that no hot and ionized gases can go outside
- The speed and the high breaking capacity give the insurance of better safety factors against equipment damages and people injury. FERRAZ SHAWMUT made a lot of tests demonstrating the arc flash energy is drastically reduced when the peak current is limited by a fuse.



Figure 1 : danger of the arc flash

Maximized energy limitation = Minimized damage & injury

2.2. Speed / peak let through current

In case of large short circuit currents nothing is faster than the fuse. The consequence is that the peak current is limited down to low values by the fuse.

This will drastically reduce the electro-dynamic forces that are proportional to the square of the peak current. It will reduce as well the I^2t and the energy passing through all components involved in the fault circuit..

Arc flash energy is as well a function of the peak current (but the equation is not a simple one)

Figure 2 illustrates clearly the advantage of the speed of the fuse:

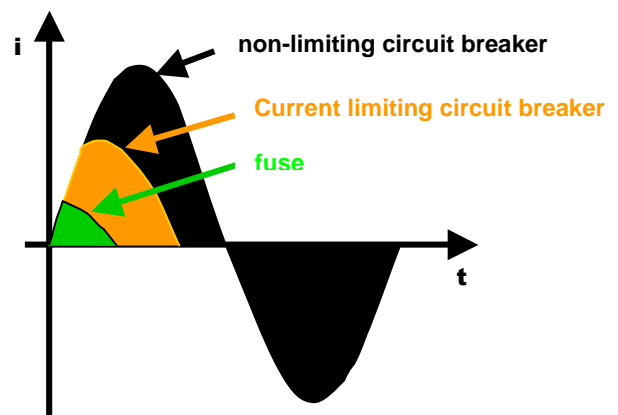

Figure 2: comparison of protective devices

fuse = energy limitation and safe breaking operation

2.3. Breaking capacity

This is the largest current the fuse can interrupt. The fuse can provide values up to 100 000 A, 200 000 A and even 300 000 A.

2.4. Maintenance before a short-circuit

No maintenance is needed because the fuse characteristics do not change.

2.5. Maintenance after a short-circuit

After the interruption of the fault current it is necessary to replace the blown fuse by a new one. However this is done quickly and gives the insurance the equipments are still protected with exactly the same efficiency as before.

2.6. Selectivity (or discrimination)

This is the coordination of the relevant characteristics of two or more protective devices such that, on the occurrence of overcurrents within stated limits, the device intended to operate within these limits does so while the other does not. With fuses the selectivity is very easily achieved. Figure 3 shows that only fuse F1 melts while all other fuses do not melt and are still as good as they were before the fault. With IEC gG fuses selectivity is achieved when F2 fuse rating is 1.6 times fuse F1 rating. Same rule applies for F3 and F2 fuse ratings.

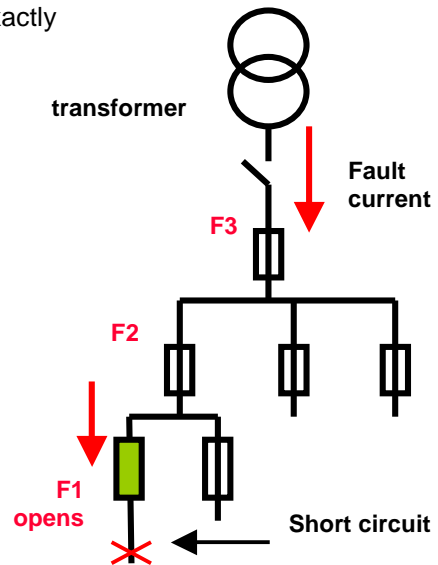

Figure 3 : selectivity

Fuse = minimized circuit disruption, no black out.

2.7. Power quality

Voltage sags caused by power-system faults can cause serious problems for computer systems, adjustable speed drives and other industrial or domestic equipment. The effect of a voltage sag depends on its magnitude and duration. Figure 4 shows the use of current-limiting fuses for system protection reduces the duration of voltage sags, without producing excessive overvoltages, thus improving the power quality.

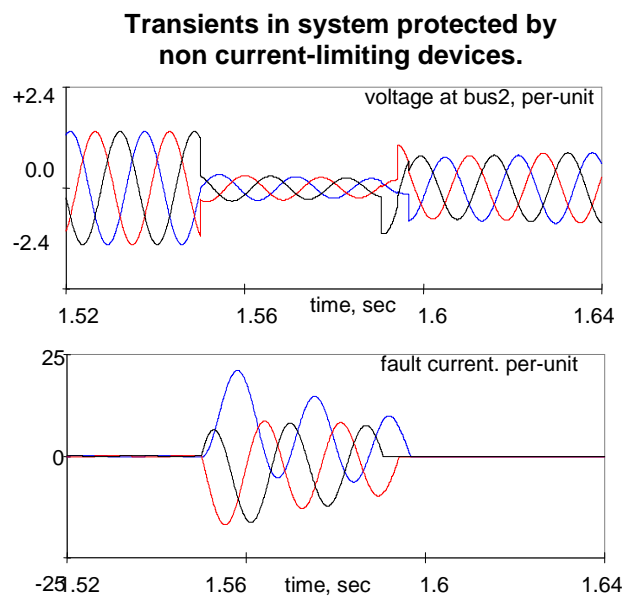
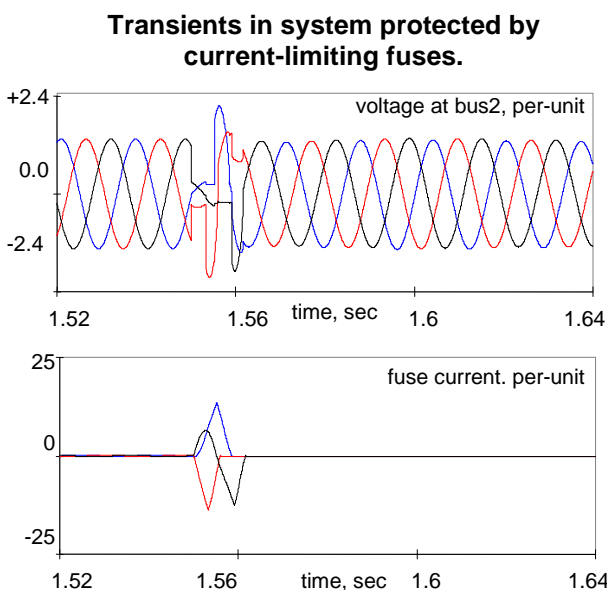

Figure 4

2.8. Future system growth

In many plants the total power increases with the time. Consequently the total short circuit currents increases as well. Breaking capacities of all protection devices must be checked. Fuses generally still comply with the new requirement owing to their initial large breaking capacities. Furthermore adding fuses to an existing system helps to upgrade the breaking capacity of the protection system.

2.9. Low power consumption

Low voltage fuses have a low power loss sometimes lower than circuit breakers power losses. For example FERRAZ SHAWMUT fuse losses are:
3 W for a 32 A gG or aM size 10x38 in our "MODULOSTAR" fuse holder (3.2 W for a circuit breaker)
5 W for a 50 A gG or aM size 14x51 in our "MODULOSTAR" fuse holder (same for a circuit breaker)
9.5 W for a 125 A aM size 22x58 in our "MODULOSTAR" fuse holder (14 W for a circuit breaker)

2.10. Reliability

The simplicity of the fuse concept provides a highly reliable protection. Obviously better than many other concepts.

2.11. Universal

Fuses can protect cables, transformers, motor circuits, capacitors, contactors, old circuit breakers and power electronic equipments; they can be selected to withstand normal operation overloads and still provide fast operation when the short circuit occurs and when there is a damaging overload sustained for a long time. They are designed for low voltage and medium voltage applications. FERRAZ SHAWMUT offers: all type of IEC 60269 fuses and all type of American fuses complying with UL 248 (class J,L, H,CC,T,RK1, RK5 etc...), medium voltage fuses as per IEC 282 , DIN43625 and American standard ANSI C37.46, DC rated fuses and the widest catalogue of fuses for semi conductors.

2.12. Price

Fuses are still the most economical protection. This is more obvious if the cost of all maintenances, power consumption and repairs are included over the years of service.

3. CONCLUSION

Alone or associated to other protection devices for optimum protection the fuse is an ideal solution in low voltage or medium voltage distribution circuits, for power electronic equipment protection and for DC or AC circuits.

F

Full overcurrent protection, **F**idelity of operation

U

Universal use (gM or gD ideal all-purpose fuse)

S

Selectivity, **S**implicity, **S**afety

E

Economical, **E**nergy-limiting, **E**asy-to-use

Simply perfect !